

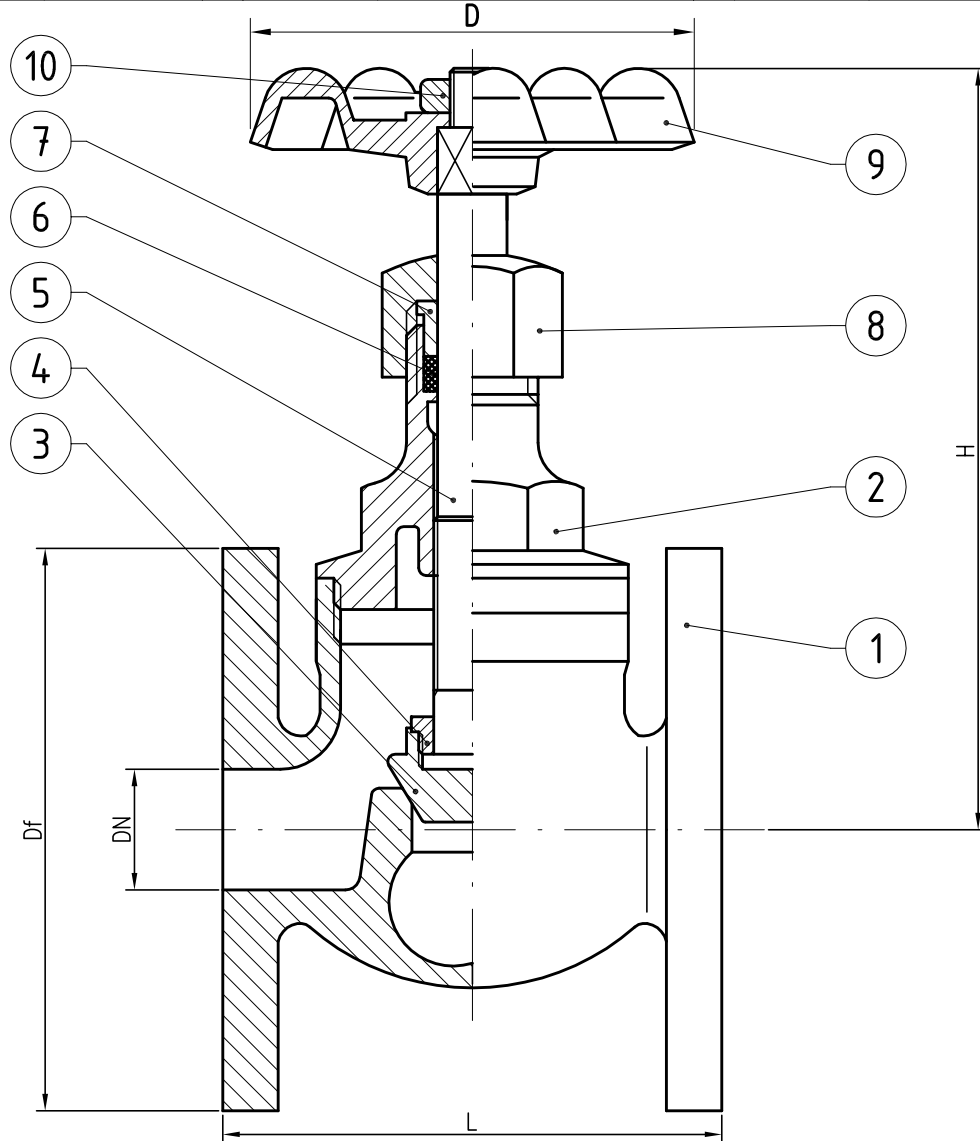



N°	NAME	MATERIAL		N°	NAME	MATERIAL		N°	NAME	MATERIAL	
1	BODY	BRONZE-CC491K UNI EN1982		4	DISC RING	BRASS-CW614N UNI EN12164		8	PACK.NUT	BRASS-CW617N UNI EN12165	BRONZE-CC491K UNI EN1982
2	BONNET	BRASS-CW617N UNI EN12165	BRONZE-CC491K UNI EN1982	5	STEM	BRASS-CW614N UNI EN12164				at 1/4" to 3"	4"
		at 1/4" to 2"	at 2"1/2 to 4"	6	PACKING	P.T.F.E.	AF/15/MA (Patented)	9	HANDWHEEL	ALUMINIUM-GD12FE UNI EN1706	
3	DISC	BRASS-CW614N UNI EN12164	BRONZE-CC491K UNI EN1982			at 1/4" to 1/2"	at 3/4" to 4"	10	WHEEL NUT	STEEL-6S UNI 5589	
		at 1/4" to 2"	at 2"1/2 to 4"	7	PACK.GLAND	BRASS-CW614N UNI EN12164		11	-	-	

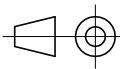

MARK \ Size	1/2"	3/4"	1"	1"1/4	1"1/2	2"	2"1/2	3"	4"
D mm	55	60	70	80	80	95	110	130	150
Df mm(PN16)	95	105	115	140	150	165	185	200	220
L mm	80	80	92	102	118	140	160	190	244
H mm	125	125	130	160	190	215	230	250	300
Wheight kg	1.850	1.900	2.400	2.950	3.600	6.300	8.700	11.800	19.500

 CONTI RUBINETTERIE di Conti Giorgio & C. S.a.s. Via Astabbio, 5 - 13018 Valduggia TELEFONO 0163 487704 FAX 0163 48107	 SCALA /	DISEGNATORE Simone Lanaro	MODIFICA: _____ _____ _____	 FIRMA _____	DATA _____		
		DATA 15-06-2006	RICAVATO DAL -	APP _____	REV _____	M.V. 15-06-06	_____
		CODICE: 80401	DESCRIZIONE: BRONZE GLOBE VALVE PN16 FLANGED ENDS METAL DISC	N° DISEGNO -	PAG. 1/1	REV. 00	A TERMINI DI LEGGE E' VIETATA LA RIPRODUZIONE O DIFFUSIONE DEL DISEGNO PREVIA NOSTRA AUTORIZZAZIONE.